

# DYZ-101 Column type load cells

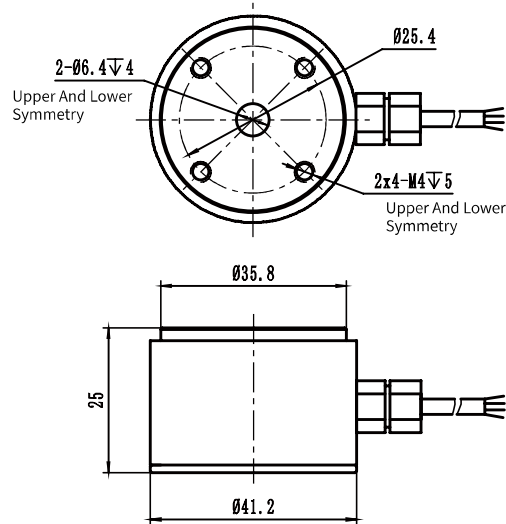

## Product Reviews

### Characteristic

Low height, large contact area, high comprehensive precision, easy to installation. Different scales and sizes can be customized.

### Application Area

It is mainly used in electronic weighing equipment and pull pressure detection equipment with large pressure area, such as:

- Pressure equipment
- Mobile phone assembly
- Small pressure platform
- tester
- Pressure installed capacity
- hydraulic press
- Cold hot press
- Electronic hook scale, hopper scale, etc

## Parameters Table

Range	0-2000kg	Material quality	Stainless Steel
Output sensitivity	2.0±0.05mV/V	Impedance	350Ω
Zero point output	±2%F.S.	Insulation resistance	≥5000MΩ/100VDC
Nolinear	0.05%F.S.	Service voltage	5-10V
Hysteresis	0.03%F.S.	Operating temperature range	-20-80°C
Repeatability	0.03%F.S.	Safe overload	150%
Creep (30 min)	0.03%F.S.	Extreme overload	200%
Temperature sensitivity drift	0.03%F.S./10°C	Cable line specifications	φ3x2m
Xero point temperature drift	0.05%F.S./10°C	Cable limit tension	10kg
Response frequency	10kHz	TEDS	

### Range (kg)

1	2	3	5	10	20	30	50
100	200	300	500	1000	2000	5000	